

# Inventory and Planning: The First Steps in Records Management

By  
Suzanne Etherington and Ann Marie Przybyla

2003

This booklet replaces the following  
State Archives publications:

Publication # 24,  
Guidelines for Planning and Conducting a Records Inventory

Publication # 43,  
Guidelines for Planning Local Government Records Programs

The University of the State of New York  
The State Education Department  
New York State Archives  
Government Records Services  
Albany, New York 12230  
<http://www.archives.nysed.gov>

THE UNIVERSITY OF THE STATE OF NEW YORK  
Regents of The University

ROBERT M. BENNETT, CHANCELLOR, B.A., M.S. ....	Tonawanda
ADELAIDE L. SANFORD, VICE CHANCELLOR, B.A., M.A., P.D. ....	Hollis
DIANE O'NEILL MCGIVERN, B.S.N., M.A., PH.D. ....	Staten Island
SAUL B. COHEN, B.A., M.A., PH.D. ....	New Rochelle
JAMES C. DAWSON, A.A., B.A., M.S., PH.D. ....	Peru
ROBERT M. JOHNSON, B.S., J.D. ....	Huntington
ANTHONY S. BOTTAR, B.A., J.D. ....	North Syracuse
MERRYL H. TISCH, B.A., M.A. ....	New York
GERALDINE D. CHAPEY, B.A., M.A., ED.D. ....	Belle Harbor
ARNOLD B. GARDNER, B.A., LL.B. ....	Buffalo
HARRY PHILLIPS, 3RD, B.A., M.S.F.S. ....	Hartsdale
JOSEPH E. BOWMAN, JR., B.A., M.L.S., M.A., M.ED., ED.D. ....	Albany
LORRAINE A. CORTÉS-VÁZQUEZ, B.A., M.P.A. ....	Bronx
JUDITH O. RUBIN, A.B. ....	New York
JAMES R. TALLON, JR., B.A., M.A. ....	Binghamton
MILTON L. COFIELD, B.S., M.B.A., PH.D. ....	Rochester

**President of The University and Commissioner of Education**

RICHARD P. MILLS

**Chief Operating Officer**

RICHARD H. CATE

**Deputy Commissioner for Cultural Education**

CAROLE F. HUXLEY

**Acting Assistant Commissioner and Director of Operations**

CHRISTINE WARD

**Chief, Government Records Services**

ROBERT W. ARNOLD

The State Education Department does not discriminate on the basis of age, color, religion, creed, disability, marital status, veteran status, national origin, race, gender, genetic predisposition or carrier status, or sexual orientation in its educational programs, services and activities. Portions of this publication can be made available in a variety of formats, including braille, large print or audio tape, upon request. Inquiries concerning this policy of nondiscrimination should be directed to the Department's Office for Diversity, Ethics, and Access, Room 530, Education Building, Albany, NY 12234. **Requests for additional copies of this publication may be made by contacting the State Archives, Grants Administration and Program Support Unit, Room 9A68, Cultural Education Center, Albany, NY 12230.**



## Table of Contents

Introduction .....	1
Planning the Inventory .....	2
Conducting the Inventory .....	3
Using the Inventory Data .....	5
Preparing a Records Management Plan .....	6
For More Information and Assistance .....	8
Appendix A: Records Inventory Data Worksheet .....	9
Appendix B: Instructions for Completing the Records Inventory Data Worksheet .....	11
Appendix C: Sample Completed Records Inventory Data Worksheet .....	19
Appendix D: Sample Inventory Database Output .....	21
Appendix E: Sample Office Map .....	22
Appendix F: Table of Cubic-Foot Equivalents .....	23
Appendix G: Sample Records Management Plans .....	24
Long-Range Records Management Plan for Capital City, 2003–2006 .....	24
Annual Records Management Plan for Capital City (2003) .....	27
Records Management Plan for North Haverbrook Central School District .....	30
Appendix H: Glossary of Records Inventory and Planning Terms .....	32



---

## Introduction

A records inventory is the foundation of sound records management, and is often the first step in establishing a records management program. No matter how you organize your records, an inventory can provide an overview that will help you manage these records in the future. During an inventory you will locate, identify, and describe all records series held by your local government or state agency, whether the records are in electronic, paper, micrographic, or any other format. At the end of an inventory, you will have a good idea of the type and quantity of records created and maintained by your local government or agency, and probably some understanding of how to manage them more efficiently.

After completing the inventory, you should conduct both an appraisal and a needs assessment to help you assemble short- and long-term plans for managing your records. These four components—inventory, records appraisal, needs assessment, and management plan—are essential steps in developing a strong records management program.

This booklet provides local governments and state agencies with advice on how and when to conduct an inventory and how to plan for the development or improvement of a records management program. Although the process of conducting an inventory may be time-consuming, in the end you should see many advantages. An inventory can

- help you manage your records more efficiently
- help local governments and state agencies meet the Freedom of Information Law requirement to maintain a subject matter list of records
- help you “clean house” by forcing staff to identify and discard unnecessary records
- teach you about the records your organization maintains, so you can formulate sound plans to guide and develop your records management program.

---

## Planning the Inventory

### Get support

Support from everyone who creates or uses records is critical for a successful inventory, since inventory workers will be in and out of storage and office areas and will probably ask the rest of the staff questions about specific records. If upper management supports an inventory, then securing cooperation from everyone else will be easier. Let staff know the purpose and timetable of the inventory and reassure them that an inventory is not an audit. The records management officer (RMO) should actively oversee the inventory, whether it is carried out by workers hired for the project or by current staff. An organizational chart will help inventory workers determine who to contact across the government or agency, and how departments and their records relate to one another.

### Set a schedule

Develop a timetable that clearly assigns responsibility for all activities, estimates the inventory schedule for each area, and allows time to both evaluate the inventory and develop a program plan. The timetable should include clear deadlines, although you may have to adjust the schedule as work progresses. The plan should lay out the schedule of department and unit inventories, with estimates of staff hours necessary to complete each task.

Estimate roughly how long an inventory will take. Most organizations should plan about one hour of inventory for each 1 to 2 cubic feet of records. The larger the number of records involved, the faster the inventory rate should proceed. Most large organizations can easily inventory at a rate of 2 cubic feet per hour, since they will have a number of very large records series that take only a little bit longer to inventory than a small series. (You can quickly inventory even a large series by looking at a set of samples from the series; there is no need to review the whole series.) If your organization has few records (750 cubic feet or less), you will probably have many more smaller series, so you should estimate an inventory rate of 1 cubic foot per hour. Keep in mind that electronic records will usually take longer to inventory because estimates by cubic feet don't work with them. The scope and complexity of this timetable will vary from one organization to another, but you should build in some review dates to monitor progress and adjust the schedule as needed.

---

## Conduct a survey

Before conducting a full inventory, you might consider doing an initial survey of your organization's records situation, beginning with the departments or offices that you think would be most cooperative. Many people use initial surveys to estimate the size of the inventory project and thus plan for it. If this is the case with you, use Appendix F, "Table of Cubic-Foot Equivalents," at the end of this booklet to help you determine the volume of records in file cabinets and other storage equipment. Other organizations might want to hire a consultant to carry out a survey in concert with a detailed analysis of the overall records system, relying on the consultant's needs assessment report in place of a full inventory. If you will hire a consultant to write your plan, see Publication # 44, *Records Management Consultants*, for direction.

## Conducting the Inventory

### Inform supervisors

A logical first step is to visit individual supervisors to explain the inventory process and how it will benefit each office. Supervisors should understand that inventory workers will need access to all records (including electronic records and those on microfilm) and that they will need to ask questions as they work. The project director should reassure supervisors and staff that the purpose of the inventory is to help them manage their files, not to criticize current filing methods.

### Draw a map of the location

Inventory staff should begin by drawing a map of the physical layout of each new area, numbering each piece of records storage equipment (such as filing cabinets and shelves), and noting the location of each records series. For an example of an office map, see Appendix E, "Sample Office Map."

---

## Collect information on each records series

The simplest approach to conducting an inventory is to describe records series, rather than whole individual folders. Using the form provided in Appendix A, “Records Inventory Data Worksheet,” inventory workers should complete one inventory worksheet per records series per location. If there are additional records in another storage area that are part of the same series, complete another worksheet for that location. This will ensure efficient access and retrieval of records after the inventory. For detailed instructions on filling out the worksheet, see Appendix B, “Instructions for Completing the Records Inventory Data Worksheet.” For an example of a completed form, see Appendix C, “Sample Completed Records Inventory Data Worksheet.”

## Store inventory data in a database

Since the inventory worksheet collects data in separate fields, you can copy the structure of the form to create an electronic inventory by using any off-the-shelf database software package. Having the inventory information in a database allows you to identify all locations of a fragmented records series. Since an automated database will help you manage your records long after the inventory has been completed, you should consider purchasing database software during the planning phase of the inventory. Contact the State Archives Regional Advisory Officer (RAO) in your region for advice on how to proceed. See Appendix D, “Sample Inventory Database Output,” for one example of how you can evaluate and use your inventory data once you have it in a database.



---

## Using the Inventory Data

After completing the worksheets, you should use the data collected to appraise the records and create a needs assessment. Only by evaluating and using the data you have collected can you guarantee a successful records inventory.

### Appraisal

Appraisal involves evaluating the records and determining their administrative, fiscal, legal, historical, and research value. Appraisal will identify

- which records are vital
- which records are archival or have a permanent retention requirement
- which records are candidates for preservation or conservation
- which records are inactive
- which records are confidential
- which records are obsolete and ready for disposal
- annual growth figures that you can use to estimate future space requirements

The appraisal should consider factors unique to your organization, evaluating records in the context of your particular needs. Your RAO is a good resource for help in appraising your records.

### Needs assessment

A needs assessment is a list of your organization's records management problems or issues, and it is based on data gathered from the inventory, discussions with supervisors and employees, observations made while conducting the inventory, and issues raised in the appraisal. Consider the following items when determining records management needs:

- Where the use of new electronic recordkeeping systems (such as an imaging system) might improve the creation and use of your records
- Production, use, and storage of duplicate copies of records

- 
- Location of unused or under-used filing equipment
  - Which records are infrequently consulted and should be moved out of offices and into a storage area
  - Which records need better filing or indexing systems to make them more accessible
  - Which records are good candidates for microfilming
  - Which records are historical
  - Whether there are storage areas that are unsuitable for records storage

After considering these issues, you can set priorities and determine how to solve the problems identified in your needs assessment. Then you will be ready for the next step—developing a plan.

## Preparing a Records Management Plan

### What is records management program planning?

You must develop a records management program that meets the current and future needs of your organization. The records inventory, appraisal, and needs assessment are the preliminary work toward a records management plan. A plan is a road map to a destination, or a set of guidelines for getting a job done. But any records management plan must be practical and realistic. Although the length, amount of detail, and exact makeup of a plan will vary, all plans will address three questions:

- What is the present situation with your government's records?
- What do you want to change or develop?
- How will you do this?

A records management plan should examine the current records situation, describe both short-term and long-term goals, and identify what resources might be needed to achieve those goals. Long-term plans usually cover a three- to five-year framework and the broader purposes of the program. Short-term plans, usually covering one year, indicate exactly what the program is expected to accomplish in the near future.

.....

An organization can prepare a records management plan at just about any point in its existence. It is desirable, but not essential, to have a records ordinance or policy statement as a point of departure for the plan. It may also be useful to have a records advisory board in place when developing and implementing the management plan. You may decide to write the plan in-house or to hire a records management consultant to write it. If hiring a consultant, see Publication # 44, *Records Management Consultants*, for direction.

## Why records program planning is important

A sound records management program plan

- provides a basis for responsible management by setting priorities
- provides staff with a common understanding of program goals and permits effective marshalling of resources
- ensures that the program proceeds according to established expectations rather than in reaction to everyday pressures and problems
- furnishes a framework for staff assignments and accountability
- provides a clear way to explain the program to governing bodies and the public
- provides a basis for budget requests

Most plans have three levels:

1. Mission statement
2. Goals
3. Objectives

This does not mean that the planning process must be long or difficult, or that the plan itself must be long and elaborate. In fact, for a plan to be viable, it must be concise, clear, realistic, and practical. Plans should be flexible, and they should meet an organization's needs rather than fit a prescribed pattern. Your Regional Advisory Officer can help you develop or review your plan. For examples of records management plans, see Appendix G, "Sample Records Management Plans."

.....

## For More Information and Assistance

The New York State Archives provides direct advice to local governments and state agencies on how to conduct a records inventory and how to plan and develop a records management program. The Archives has regional offices throughout the state, and each office has a records specialist who can visit you and provide technical advice and assistance. Archives services also include publications and workshops on a wide variety of records management topics. For further information, contact your regional office, or

Government Records Services  
New York State Archives  
State Education Department  
9A47 Cultural Education Center  
Albany, New York 12230  
[www.archives.nysed.gov](http://www.archives.nysed.gov)  
(518) 474-6926

## Appendix A

### Records Inventory Data Worksheet

Form is available on the facing page

# Records Inventory Data Worksheet

See instructions in Publication #76, *Inventory and Planning*, before completing this form.

<b>1a. GOVERNMENT/AGENCY</b>	<b>1b. DEPARTMENT/UNIT</b>
<b>2. RECORDS SERIES TITLE</b>	
<b>3. DATE SPAN</b>	
<b>4. RECORDS SERIES DESCRIPTION</b> (Describe content and characteristics of records)	
<b>5. ARRANGEMENT</b> <input type="checkbox"/> Alphabetical <input type="checkbox"/> Numerical <input type="checkbox"/> Chronological <input type="checkbox"/> Alphanumeric <input type="checkbox"/> Other (Specify):	
<b>6a. RETENTION</b> <input type="checkbox"/> Not scheduled <input type="checkbox"/> Permanent <input type="checkbox"/> Appraise for historical value <input type="checkbox"/> Scheduled retention:	
<b>6b. SCHEDULE AND ITEM NUMBER, OR REASON FOR PROPOSED RETENTION</b>	
<b>7. LOCATION</b>	
<b>8. FORMAT</b> <input type="checkbox"/> Paper <input type="checkbox"/> Audiovisual <input type="checkbox"/> Micrographic <input type="checkbox"/> Electronic	
<b>9. TOTAL QUANTITY</b> (In cubic feet <i>or</i> number of items): <input type="checkbox"/> Cubic feet: <input type="checkbox"/> Items:    Type of items:	
<b>10. ANNUAL ACCUMULATION</b> (In cubic feet <i>or</i> number of items): <input type="checkbox"/> Cubic feet: <input type="checkbox"/> Items:	
<b>11. FREQUENCY OF USE:</b> <input type="checkbox"/> Daily <input type="checkbox"/> Weekly <input type="checkbox"/> Monthly <input type="checkbox"/> Seldom <input type="checkbox"/> Never	
<b>12. RESTRICTIONS ON USE</b>	
<b>RECORDS ARE</b> <b>13. <input type="checkbox"/> IN POOR CONDITION</b> <b>14. <input type="checkbox"/> VITAL</b> (Essential to operations) <b>15. <input type="checkbox"/> OFFICIAL COPIES</b>	
<b>16a. NAME OF PERSON COMPLETING FORM</b>	<b>16b. DATE</b>



.....

## Appendix B

### Instructions for Completing the Records Inventory Data Worksheet

Use the Records Inventory Data Worksheet when conducting your inventory to help ensure consistent and complete data collection. Information gathered in the worksheets

- forms the basis for analyzing your needs and developing a records management plan
- can serve as an interim way to locate records
- can be entered into a records management database and locator system

The State Archives requires all local governments with inventory projects funded by the Local Government Records Management Improvement Fund (LGRMIF) to use the Records Inventory Data Worksheet.

As you fill out the data worksheets, keep in mind that someone other than yourself might need and use them in the future. You should therefore avoid using jargon, informal titles, abbreviations, or proper names of current officeholders to describe your records. There are a number of ways to make your inventory more efficient:

- Use pencil to complete the forms, because data can change as you work your way through the records.
- Fill in repetitive fields such as “government/agency” and “department/unit” before photocopying a supply of worksheets for the inventory.
- Do not inventory non-records, such as blank forms, personal papers, and publications from an outside source.
- Do not inventory records that have met their legal retention period. Instead, log information from those records on a disposition authorization form, and discard the records after receiving the necessary approvals.
- If a field on the form limits the amount of detail that you can provide concerning the records, give clarification or more information in the series description (field 4).

.....

## 1a. Government/Agency

Give the full and unabbreviated name of the local government or state agency whose records are the subject of the inventory.

Examples:

- Department of Environmental Conservation (*not* EnCon or DEC)
- Fire Island Union Free School District (*not* Fire Is. Schl. Dist.)
- Town of Colonie (*not* Colonie)

## 1b. Department/Unit

Give the full name of the subdivision that creates, uses, and maintains the records series. Do not use the proper name of an official unless it is the name of the department. Examples:

- County Clerk (*not* Clerk)
- Personnel Office (*not* Personnel)
- Treasurer's Office (*not* Bob Clark's Office)

## 2. Records Series Title

Determine a specific, descriptive title after looking at the records. You can also use a relevant records retention and disposition schedule to arrive at appropriate records series titles. Titles should denote the subject, function, and/or form of the records. Examples:

- Budget Preparation Files
- Commissioner's Correspondence File
- Construction Photographs
- Consumer Case Files

If the records series has a common or colloquial name, note this name in the series description (field 4).

## 3. Date Span

Provide the beginning and ending dates of the records series (e.g., 1978–1990). For ongoing series use “9999” as the end date (e.g., 1971–9999) or use the word “current” or “ongoing.” (Using a set number such as “9999” allows you the ability to search and sort on that number if you maintain your data in a database.) Use “ca.” for



.....

circa, meaning “approximately,” when you cannot determine exact dates (e.g., ca. 1977–ca. 1991). If there are significant gaps in the date span, indicate them in the series description (field 4).

## 4. Records Series Description

The description helps you match records series to relevant schedule items, determine how long to retain unscheduled records, and appraise records for ongoing historical significance. It should include basic information concerning the contents and purpose of the records series. You can also indicate any gaps in dates, particularly significant items found in the series, or common or colloquial names used to describe the series.

### For Electronic Records

Descriptions of electronic recordkeeping systems should indicate names of software and hardware required for access, as well as the data formats of the records. You should also provide a brief description of any electronic or other files that support or run the system, including indexes, data dictionaries, metadata documentation, or other files that may exist in other formats.

### Sample Series Descriptions

- Series consists of building permits and supporting materials such as maps, drawings, specifications, and inspection reports. It contains information on construction companies, building locations, building materials, and code violations. The series documents changes to individual residential and commercial properties in the city.
- Tax assessment rolls consisting of handwritten lists with names of property owners, acreage, value of real estate, value of personal property, total value, and total tax. Some rolls may contain a description of property such as “farm lot” or “mill.” All rolls contain description of non-resident lands, usually at the end of the roll. The series provides a record of assessment of resident and non-resident property situated in the town and is used for raising tax revenues to support town government and services.
- Training files include lesson plans, copies of examinations, training schedules, photographs of training classes. Series also includes data on the first training program (1975) for women firefighters.
- Correspondence files, consisting of outgoing correspondence maintained in Microsoft Word 97 and Millennium formats and

.....

incoming correspondence maintained as 8-bit black-and-white TIFF images, stored on server space and backed up weekly.

- Electronic social services case files are stored in a database that includes digital images (TIFF) of incoming paperwork (for example, copies of birth certificates), along with electronic copies of reports filed by caseworkers. Specific vital information is maintained in the database on each individual, including name, sex, address, and date of birth. The record copy of the full data dictionary that explains the information in each field of the database, and a procedures manual for entering and verifying the accuracy of information, is maintained by the Office of the Commissioner of Social Services. For some files before 1998, there may be additional paper documents maintained in other locations.

## 5. Arrangement

Indicate how the records are organized (alphabetical, numerical, chronological, or alpha-numeric order). An alpha-numeric arrangement combines alphabetical and numerical systems, using codes such as “HWY-01.” If the arrangement is complicated, check “other” and describe. For example:

- Chronologically by year of graduation, then alphabetically by student name
- Numerically by tax parcel map number, then by document type (blueprints, permits, specifications, or variances)

## 6a. Retention

Use this field to indicate the minimum amount of time that you must retain the records according to a State Archives or other retention and disposition schedule. For advice on using retention schedules, refer to Publication #41, *Retention and Disposition of Records*. Either fill in the specific period of time mandated (such as “6 years after audit”) or check “Permanent,” as appropriate.

If the series is not in any schedule, check “Not Scheduled.” You may also use this line to propose a reasonable retention period. Use this when your local government wishes to keep the series beyond the set retention period, or if you are a state agency dealing with records that you have not scheduled. State agencies should also include information on what causes the records to become inactive.

If you think the records should be evaluated to determine whether they should be kept beyond a mandated retention period, check “Appraise for Historical Value.”

.....

## 6b. Schedule and Item Number, or Reason for Proposed Retention

Indicate the State Archives or other schedule (such as a schedule for court records issued by the Office of Court Administration), and provide the appropriate item number covering the series at hand. If the records are not scheduled but you proposed a retention in line 6a, explain the rationale behind that retention period.

## 7. Location

Indicate the location of the records in enough detail to help you and others find them after the inventory is complete. The location can include building, room, cabinet (and drawer), shelf, and box. For example:

- Annex building, Planner's Office, Desk 2, Drawer 1
- Elementary School, Room 125, Cabinet 1, Drawers A–D
- Upstairs vault, Shelf A-1, Box 3

## 8. Format

Check all formats that apply to the records series. Paper records include loose documents, bound volumes, photographs, architectural drawings, and maps. Audiovisual records can include records stored on audio- and videotapes, compact discs (CDs), phonorecords, and digital video discs (DVDs). Micrographic records can be microfilm rolls or microfiche. Electronic records include word-processed files, databases, electronic spreadsheets, geographic information system (GIS) records, computer-aided design (CAD) records, and e-mail.

## 9. Total Quantity

This information is important for determining the resources—filing equipment, shelving, boxes, and labor—required to care for your records. Indicate quantity of paper records in cubic feet. See Appendix F, “Table of Cubic-Foot Equivalents,” for information on how to estimate the cubic footage of paper records.

For records in other formats, quantify the volume by number of items, which can include rolls, tapes, CDs, and disks. Quantify records in electronic recordkeeping systems by number of bytes or by number of items (such as CD-ROMs and computer tapes).

.....

## 10. Annual Accumulation

Annual accumulation is the volume of records created, received, and retained in the course of a year. Collect this data only for records stored in offices. Indicate the rate—in cubic feet or number of items—at which these records grow every year, using the most recent year or two as a guide. You can use this information for projecting future space needs for inactive records.

## 11. Frequency of Use

Indicate how often both office staff and others use the records. This information will help you determine whether you should transfer records in office areas to inactive storage, or whether you should make records stored in remote inactive areas more physically accessible.

## 12. Restrictions on Use

Indicate whether there are any restrictions on who may view records in the records series. Sometimes, a specific law requires you to keep the records confidential. In such cases, you should cite the law or regulation that mandates restrictions. Occasionally you may have to restrict use, because allowing use would cause damage to fragile historical records. However, do not identify a series as restricted or confidential merely because your government or agency routinely requires written requests for access to records.

If you are not sure whether records are restricted, contact the New York State Committee on Open Government by mail at 41 State Street, Albany, NY 12231-0001, by telephone at (518) 474-2518, or by e-mail at [opengov@dos.state.ny.us](mailto:opengov@dos.state.ny.us)

## 13. Records are in Poor Condition

If part or all of the records series are damaged, check the box. Examples of damage include tears, stains, folding, mold, mildew, brittleness, and discoloration. This field is useful for identifying records series for microfilming or individual documents that may require the care of a professional conservator. If there is a pattern of damage among records stored in the same area, it may also indicate chronic problems with your storage environment, such as excessive or variable temperature and humidity.

.....

#### 14. Records are Vital

Check the box if these are vital records, which are those that are essential to the daily operation of your organization. Don't confuse this use of the term "vital records" with "vital statistic" records such as birth, death, and marriage certificates. Examples of vital records are current tax receipts, ongoing contracts, payrolls, and land and student records.

#### 15. Records are Official Copies

Check the box if this particular copy of the records being inventoried is the "official copy." The official copy is usually the clearest, most complete, signed and/or certified copy. Sometimes there are two equally good sets of one records series; in such cases, you may have to designate an official copy if one is not immediately apparent. Retention and disposition schedules require that you retain only the official copy of any record; you may destroy duplicates when no longer needed.

#### 16a. Name of Person Completing Form

Provide the name of the person who inventoried this records series.

#### 16b. Date

Provide the date that the worksheet was completed. This information is useful in determining whether or not the inventory is up to date.



# Appendix C

## Sample Completed Records Inventory Data Worksheet

Records Inventory Data Worksheet	
See instructions in Publication #76, <i>Inventory and Planning</i> , before completing this form.	
1a. GOVERNMENT/AGENCY	1b. DEPARTMENT/UNIT
City of Shelbyville	Building Department
2. RECORDS SERIES TITLE	
Building Permits	
3. DATE SPAN	
ca. 1935 - 9999	
4. RECORDS SERIES DESCRIPTION (Describe content and characteristics of records)	
Series consists of building permits and supporting materials such as maps, drawings, specifications, and inspection reports. It contains information on construction companies, building locations, building materials, and code violations. The series documents changes to individual residential and commercial properties in the city.	
5. ARRANGEMENT	
<input type="checkbox"/> Alphabetical <input type="checkbox"/> Numerical <input type="checkbox"/> Chronological <input checked="" type="checkbox"/> Alphanumeric <input type="checkbox"/> Other (Specify):	
6a. RETENTION	
<input type="checkbox"/> Not scheduled <input type="checkbox"/> Permanent <input type="checkbox"/> Appraise for historical value <input checked="" type="checkbox"/> Scheduled retention: 6 years after building no longer exists (if permit granted) 6 years after final decision (if permit denied)	
6b. SCHEDULE AND ITEM NUMBER, OR REASON FOR PROPOSED RETENTION	
MU-1, 60c	
7. LOCATION	
City Hall, Room 222, Cabinets 1-13	
8. FORMAT	
<input checked="" type="checkbox"/> Paper <input type="checkbox"/> Audiovisual <input type="checkbox"/> Micrographic <input type="checkbox"/> Electronic	
9. TOTAL QUANTITY (In cubic feet or number of items):	
<input checked="" type="checkbox"/> Cubic feet: 95 <input type="checkbox"/> Items:                    Type of items:	
10. ANNUAL ACCUMULATION (In cubic feet or number of items):	
<input checked="" type="checkbox"/> Cubic feet: 3 <input type="checkbox"/> Items:	
11. FREQUENCY OF USE	
<input checked="" type="checkbox"/> Daily <input type="checkbox"/> Weekly <input type="checkbox"/> Monthly <input type="checkbox"/> Seldom <input type="checkbox"/> Never	
12. RESTRICTIONS ON USE	
None known, although the federal Patriot Act may apply some	
RECORDS ARE	
13. <input type="checkbox"/> IN POOR CONDITION	
14. <input type="checkbox"/> VITAL (Essential to operations)	
15. <input checked="" type="checkbox"/> OFFICIAL COPIES	
16a. NAME OF PERSON COMPLETING FORM	16b. DATE
Martin Prince	04/04/2004





.....

## Appendix D

### Sample Inventory Database Output

Once you have entered your inventory data into a database, you can view and print out the data in many different ways. This can help you better analyze and use the data. Below is a simple form used by a county to list alphabetically all the records series maintained by one department (the County Clerk's Office). This report gives only the title, the schedule item that proves the required retention period, and the retention period, but it provides an easy way to verify what records the department maintains. Depending on its needs, the county could adjust this report to add new pieces of information (for example, location, quantity, and format).

#### Listing of Records in the County Clerk's Department

Title: **Administrative file** (Records Management)  
Schedule item: LGS-1, General, 53c: correspondence  
Retention: 1 year

Title: **Adoptions**  
Schedule item: OCA, Civil Court & County Adoptions, 20010  
Retention: PERMANENT

Title: **Affidavits and orders**  
Schedule item: OCA, Civil Court Supreme & County:  
other case files, 20230  
Retention: PERMANENT

Title: **Annual report of the Board of Excise**  
Schedule item: LGS-1, General, 74  
Retention: PERMANENT

Title: **Annual reports of corporations**  
Schedule item: LGS-1, County Clerk, Miscellaneous, 298  
Retention: PERMANENT

Title: **Application to use records** (Records Management)  
Schedule item: LGS-1, Archives/RM, 94a  
Retention: 6 years

Appendix E

Sample Office Map

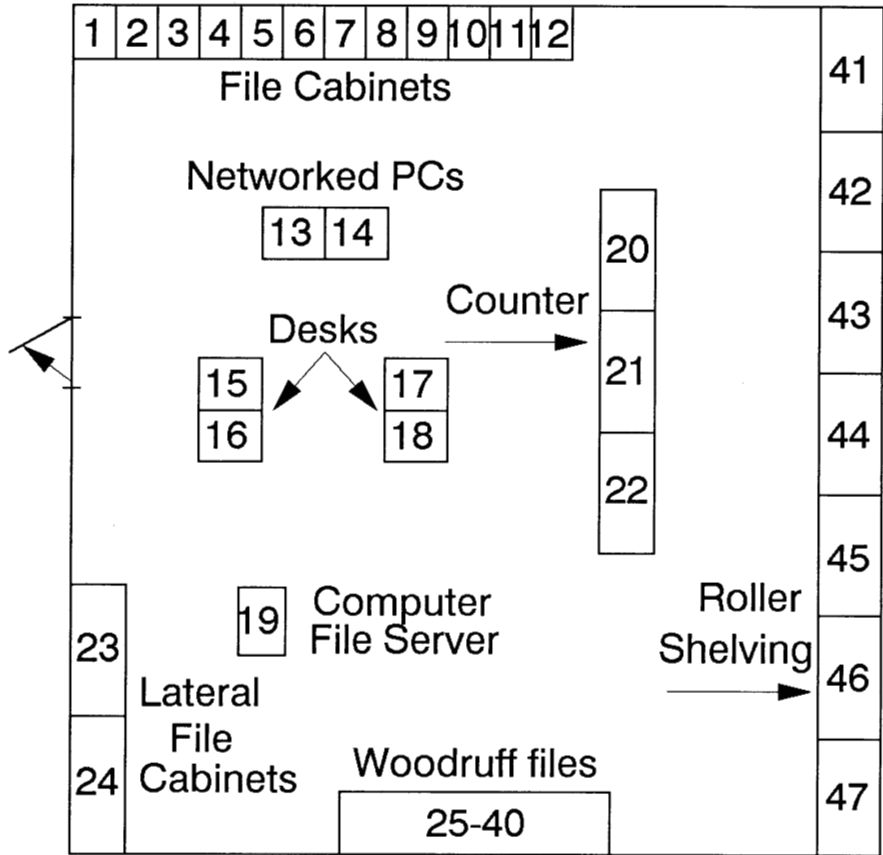

Office:	City Clerk's Office
Building:	City Hall
Address:	123 Main Street
	Everytown, New York
Room No.:	Rm. 123
Map Drawn By:	Jane Smith
Date:	December 1995

## Appendix F

### Table of Cubic-Foot Equivalents

<b>File Folder Drawers</b>	<b>cubic feet</b>
Letter	1.5
Letter Lateral	2
Legal	2
Legal Lateral	2.5
<b>Shelf Units</b>	
Letter, 36" long	2.4
Legal, 36" long	3
<b>Records Storage Containers</b>	
Standard (10" × 12" × 15")	1
Tab (.5" × 8" × 14")	0.2
Check (3.5" × 8" × 24")	0.4
Map (6" × 6" × 36")	0.7
Map (6" × 6" × 48")	1
Map (4" × 4" × 48")	0.4
<b>Map or Plan Drawers</b>	
2" × 26" × 38"	1.1
2" × 38" × 50"	2.2
4" × 26" × 38"	2.3
4" × 38" × 50"	4.4
<b>Map or Plan Tube</b>	
2" × 2" × 38"	0.1
2" × 2" × 50"	0.1
4" × 4" × 38"	0.3
4" × 4" × 50"	0.5

#### **Other Situations**

**Step 1:** Multiply length × width × height (in inches)

**Step 2:** Divide by 1,728 = cubic feet

---

## Appendix G

### Sample Records Management Plans

The first two samples form a pair of interrelated short- and long-term plans for the mythical government of Capital City. The last sample is a simple long-term plan for the North Haverbrook Central School District, a small imaginary government.

#### *Long-Range Records Management Plan for Capital City, 2003–2006*

*In this long-range plan, a medium-sized city that recently completed a records inventory has developed a four-year records management plan. The plan includes a concise mission statement for the city's records management program and five goals, each supported by specific objectives. The plan is general, but provides a good sense of how the city's records management program is progressing.*

#### Introduction

Capital City's records management ordinance, adopted by the city council, authorized and required the development of a records management plan. The city clerk (Capital City's designated Records Management Officer) developed this plan with advice and review by the Records Advisory Board. The mayor and the city council approved the plan on November 4, 2002.

#### Mission

The Capital City records management program encourages and coordinates the systematic, cost-efficient creation, maintenance, use, and disposition of official city government records.

.....

## Program Goals and Objectives, 2003–2006

### **Goal I**

Systematically dispose of records in accordance with state schedules and local procedures.

- A. Adopt and continually apply State Archives records retention and disposition schedules as they are issued, for the systematic disposition of records.
- B. Develop office schedules (tied to and compatible with State Archives schedules) to guide the retention and disposition of records in all Capital City offices.
- C. Develop and apply policies and procedures for the disposal of obsolete records that ensure approval by the originating office, protect confidential information, and maintain a listing of records destroyed.

### **Goal II**

Develop and operate a program for the management of inactive records.

- A. Identify appropriate space in City Hall for conversion to an inactive records storage area, and renovate the space as needed to ensure secure, cost-effective storage.
- B. Develop policies and procedures for coordinating an inactive records program through the city clerk's office.
- C. Develop and maintain an information locator system to records in the city's inactive records storage area.

### **Goal III**

Develop a program to microfilm appropriate records in accordance with State Archives quality guidelines.

- A. Continue and refine the existing microfilm operation in the Police Department and develop acceptable quality controls and inspection procedures in accordance with State Archives regulations.
- B. Analyze records in the city's departments to identify those best suited for microfilming.



#### **Goal IV**

Develop a program to manage the city's electronic records.

- A. Develop policies on the purchase and use of computer equipment.
- B. Develop standards for computer software and systems in city offices.
- C. Develop policies and procedures to ensure the reliability, security, retention, and preservation of electronic records in city departments.

#### **Goal V**

Develop a program for the preservation and use of historical records.

- A. In concert with the search for a storage location for inactive records, identify an appropriate space in City Hall for the storage of historical records and an accompanying research area, and renovate space as needed.
- B. Develop a plan to organize, improve access to, and encourage use of the historical records of the city.
- C. Identify preservation problems with the city's historical records and develop a plan for addressing these issues.

.....

## ***Annual Records Management Plan for Capital City (2003)***

*This annual workplan is based on the city's long-range records management plan. The annual plan includes several annual goals, each of which supports a specific goal in the city's long-range plan.*

### **Long-Term Goal I**

Systematically dispose of records in accordance with state schedules and local procedures.

#### **Annual Goal A**

Hold a workshop for records coordinators and other appropriate personnel in the use of retention schedules for the disposition of records.

#### **Annual Goal B**

Compare records disposition requests from city departments to the citywide records inventory to determine if departments are disposing of records on schedule.

#### **Annual Goal C**

Develop an office schedule for the Office of the City Clerk, based on the results of the 2002 inventory and *Retention and Disposition Schedule for New York Local Government Records (LGS-1)*.

#### **Annual Goal D**

Develop procedures for the destruction of records.

1. Discuss with the city counsel's office the city's obligations for ensuring confidentiality during the disposition process.
2. Develop a system of approvals for any records dispositions.
3. With Department of Public Works arrange for periodic, controlled disposal and recycling of city records.

### **Long-Term Goal II**

Develop and operate a program for the management of inactive records.

#### **Annual Goal A**

Develop specifications and a proposal for an inactive records storage area.



1. Assemble technical information on records centers.
  - a. Visit the cities of Shelbyville and Springfield to collect information on their records centers and inactive records programs.
  - b. Secure and compile information from the State Archives, the National Fire Protection Association, and other appropriate sources.
2. Develop an estimate of the capacity required for such a facility, based on 2002 records inventory.
3. Develop a proposal for consideration by the city council that includes specifications and estimated costs for the facility.

## Long-Term Goal III

Develop a program for microfilming appropriate records in accordance with State Archives quality guidelines.

### **Annual Goal A**

Develop a system for microfilming city records overseen by the city clerk.

1. Develop procedures for identifying priority records for microfilming.
2. Develop procedures for preparing records for filming and for conducting microfilm quality control.
3. Identify a company to provide offsite storage for the master copy of all microfilm.

### **Annual Goal B**

Cooperate with the police department's records coordinator to refine and expand the police department's microfilm program.

1. Assess the existing program, determining if procedures for records preparation, microfilming, and quality control of film meet State Archives guidelines.
2. Identify additional police department records that warrant microfilming.



---

## Long-Term Goal IV

Develop a program to manage the city's electronic records.

### **Annual Goal A**

Review the 2002 inventory to verify that all major electronic recordkeeping systems were inventoried.

### **Annual Goal B**

Develop, with the Records Advisory Board, a request for proposals to hire a consultant to evaluate the state of electronic records management in the city and to recommend improvements.

## Long-Term Goal V

Develop a program for the preservation and use of historical records.

### **Annual Goal A**

In concert with the search for a site for an inactive records storage area, identify an appropriate space in City Hall for the storage of historical records and for a research area.

.....

## *Records Management Plan for North Haverbrook Central School District*

*After conducting a complete inventory, the North Haverbrook Central School District developed the following general plan for developing its records management program over the next five years.*

### Year 1

#### Set Up a Records Center

- Find an appropriate and ample location
- Apply for an inactive records grant from the State Archives
- With grant funds, modify the location, set up shelving, and box records
- Assign responsibility for maintaining the records center

### Year 2

#### Begin Microfilming Student Records

- Consolidate the records of students who graduated six or more years ago
- Apply for a microfilming grant from the State Archives
- With grant funds, organize, purge and microfilm the records
- Set up a future schedule for microfilming records using local funds

### Year 3

#### Overhaul the Payroll and Personnel Systems

- Review possible software solutions to replace current systems
- Decide whether a needs assessment will be required
- Conduct a needs assessment (if necessary) and decide on a solution
- Apply for an active records grant from the State Archives
- Put the new system in place
- Design a way to pay for future improvements
- Design a method to maintain the records electronically

.....

## Year 4

### Control Historical Records

Identify all the historical records in the district

Apply for a historical records grant to organize the oldest of these

Organize and produce a guide to the district's historical records

Use records in displays and brochures for the district's fiftieth anniversary

## Year 5

### Use District Records in the Classroom

Introduce teachers to the historical records available in the district

Encourage a group of teachers to apply for an educational uses grant

Complete the grant project

Distribute the resulting materials across the district

Continue to use these records in projects in the school

.....

## Appendix H

### Glossary of Records Inventory and Planning Terms

**active record.** a record used frequently (at least once per month per file drawer for paper records)

**administrative value.** the usefulness of a record to an organization in the conduct of its daily business

**alphabetic arrangement.** the ordering of a records series by the letters in titles of the files within the series, such as name or subject

**alphanumeric arrangement.** the ordering of a records series by means of a classification system that uses filing codes consisting of combinations of letters and numbers

**annual accumulation.** the volume of records created, received, and retained in the course of a year

**appraisal.** the process of evaluating records based on their value to an organization, particularly when used to determine if the records have permanent historical value

**archival record.** a record that should be kept permanently because of its administrative, legal, fiscal, or research value; also called “historical record”

**arrangement.** the act or result of placing records in a particular order

**audiovisual record.** a record stored on a medium that must be accessed through a machine other than a computer (examples include motion pictures and audiotapes of meetings)

**CAD or CADD.** See “computer-aided drafting and design (CAD or CADD)”

**chronological arrangement.** the ordering of a records series by date of the individual records

**computer-aided drafting and design (CAD or CADD).** any system for computer-aided rather than manual drafting and design that displays data spatially on a predefined coordinate grid system, allowing data from different sources to be connected and referenced by location

**confidential record.** a record that is not open to the public, often to protect the privacy rights of individuals; sometimes called “restricted record”

**conservation.** the repair and stabilization of damaged documents

**cubic foot.** a standard measurement for the volume of records, equaling 1,728 cubic inches

**data dictionary.** a formal description of the information contained in a database (including format, definition, structure, and usage)

**data format.** a specific type of computer file, such as a Microsoft Word 97 file or a JPEG image file; sometimes called “file format”

**data migration.** See “migration”

**database.** a computer file that stores data structured in a way that allows for easy and specific access to information it contains

.....

**date span.** the period of time covered by a certain set of records

**disposition.** the final action performed upon records: either destruction or transfer to an archives

**duplicate.** (noun) an extra copy of a record

**electronic information system.** a computer-based system that supports the acquisition, creation, storage, processing, management of, and/or access to information

**electronic record.**

*(definition from ESRA)* “information, evidencing any action, transaction, occurrence, event, or other activity, produced or stored by electronic means and capable of being accurately reproduced in forms perceptible by human sensory capabilities”

*(simple definition)* a record that is in electronic form

**electronic recordkeeping system.** an electronic information system that supports the collection, organization, and categorization of electronic records

**Electronic Signatures and Records Act (ESRA).** New York legislation passed in 1999 to ensure that electronic signatures are legally binding in government and to clarify the authority of New York government entities to create and maintain records created by computers in electronic form.

**ESRA.** See Electronic Signatures and Records Act (ESRA)

**field.** a location in a database that stores a particular type of data (such as an address field, a city field, a state field, etc.)

**file.**

*(noun)* a collection of related records that are treated as a unit, sometimes used synonymously with “records series” and sometimes referring to the contents of one case or file folder

*(verb)* to arrange documents in a logical sequence, or to place a document in its appropriate location within a set of records

**file format.** See “data format”

**filing system.** a pre-defined plan using numbers, letters, or keywords to identify and organize records in a systematic scheme

**fiscal value.** the usefulness of a record in documenting financial decisions and activities

**geographical information system (GIS).** a computerized database system used to gather, manipulate, display, and analyze spatial data (including maps, three-dimensional models, and tables)

**GIS.** See “geographic information system (GIS)”

**historical record.** a record that should be kept permanently because of its administrative, legal, fiscal, or research value; also called “archival record”

**historical value.** the value of a record to support historical research

**inactive record.** a record accessed infrequently (for paper records, less than once per month per file drawer) but that is not yet ready for disposition

**inactive storage.** the maintenance of inactive records in a storage area separate from an active office

.....

**index.** an information guide that identifies the location of specific pieces of information within a document or a set of documents (for example, an index to a set of minutes could list topics and when they were discussed, or an index to personnel files could list the names of people included)

**indexing.** the process of designing a guide to identify and locate specific pieces of information within the records of an organization

**inventory.** See “records inventory”

**legal value.** the usefulness of a record in supporting an organization’s business agreements and ownership rights, and in documenting the rights of citizens

**LGRMIF.** See “Local Government Records Management Improvement Fund (LGRMIF)”

**life cycle.** the span of time a record exists, from its creation through its useful life to its final disposition or retention

**Local Government Records Management Improvement Fund (LGRMIF).** a dedicated fund to improve records management and archival administration in New York State’s local governments, comprised of fees collected by county clerks and the New York City Register for the recording of selected documents

**medium (storage).** a physical material that can record information, such as magnetic tape, optical disc, paper, or microfilm; also called “storage medium”

**metadata.** information describing a set of data (such as the subject, date, and recipients of an e-mail record)

**microfiche.** a sheet of microfilm containing multiple images in a grid pattern

**microfilm.**

*(noun)* fine-grain, high-resolution photographic film capable of recording images, especially when referring to such film stored on reels

*(verb)* to capture images of documents on such film

**micrographic record.** a document stored as a miniature image on microfilm or microfiche

**migration.** the periodic transfer of data from one electronic format to another, retaining the integrity of the data and allowing users continuing access to the data in the face of changing technology; sometimes called “data migration”

**needs assessment.** a process that systematically examines a records management problem, evaluates options, and recommends solutions via a formal report

**numerical arrangement.** the ordering of a records series by file number

**obsolete record.** a record that has met its retention period, is no longer useful to the organization, and that may be destroyed

**official copy.** an original record or a copy of an original record, that is used to meet the minimum retention period for that record; also called “record copy”

**official record.** a record produced or received in the formal conduct of an organization’s business

**paper record.** a document that is recorded on paper, such as a memo or map

.....

**phonorecord.** a plastic disc with a spiral groove etched over its faces, in which sound is recorded that can be played back by running a stylus in the grooves

**preservation.** the use of procedures and environmental standards to minimize the deterioration of records

**RAO.** See “regional advisory officer (RAO)”

**record.**

*(informal definition)* information, in any format, that is created by an organization or received in the formal operation of its responsibilities

*(legal definition for local governments in New York State)* any book, paper, map, photograph, microphotograph or any other information storage device regardless of physical form or characteristic which is the property of the state or any state agency, department, division, board, bureau, commission, county, city, town, village, district or any subdivision thereof by whatever name designated in or on which any entry has been made or is required to be made by law, or which any officer or employee of any said bodies has received or is required to receive for filing

*(legal definition for state agencies in New York State, plural)* all books, papers, maps, photographs, or other documentary materials, regardless of physical form or characteristics, made or received by any agency of the state or by the legislature or the judiciary in pursuance of law or in connection with the transaction of public business and preserved or appropriate for preservation by that agency or its legitimate successor as evidence of the organization, functions, policies, decisions, procedures, operations, or other activities, or because of the information contained

**record copy.** See “official copy”

**records center carton.** a box, usually made of corrugated cardboard, that is designed to hold approximately one cubic foot of legal- or letter-size records and that measures 10” x 12” x 15”

**records inventory.** the process of locating, identifying, and describing the records maintained by an organization; sometimes called “inventory”

**records management.** the systematic control of all records in an organization throughout their life cycle

**records management officer (RMO).** the person responsible for overseeing a records management program for a state agency or local government in New York State

**records management plan.** a written document that outlines a strategy to implement or improve the records management program of an organization

**records management program.** a coordinated set of policies, procedures, and activities that manage an organization’s recorded information

**records retention.** See “retention”

**records retention and disposition schedule.** a list of records series titles that indicates the length of time to maintain each series; also called a “records schedule” or a “retention schedule”

**records schedule.** See “records retention and disposition schedule”

.....

**records series.** a group of related records (such as minutes of a board, payrolls, and purchase orders) that are normally used and filed as a unit and that normally have the same retention requirements

**records survey.** a review that gathers basic information about the quantity, type, function, location and arrangement of records in an organization

**reference frequency.** the rate at which people use a set of records

**regional advisory officer (RAO).** a representative of the New York State Archives who provides records management advice to local governments and state agencies in a particular region of the state

**research value.** the usefulness of a record in supporting historical and other research

**restricted record.** See “confidential record”

**retention.** the act of keeping records for the time required, given their administrative, fiscal, legal, or historical value and use; also called “records retention”

**retention period.** the amount of time a record must be kept to meet administrative, fiscal, legal, historical or use requirements

**retention schedule.** See “records retention and disposition schedule”

**RMO.** See “records management officer (RMO)”

**schedule.**

*(noun)* See “records retention and disposition schedule”

*(verb)* to determine and formalize the retention period for a records series

**schedule item.** an entry in a records schedule that describes and gives the retention period for certain records

**security.** the protection of records by controlling which users can access which documents and for what purpose

**series.** See “records series”

**series description.** written information about a logical grouping of records, including title, date span, quantity, arrangement, and an explanation of content

**State Archives.** the New York State Archives, which provides records management and archives services to local governments and state agencies

**Storage medium.** See “medium”

**survey.** See “records survey”

**vital record.**

*(records management definition)* a record essential for protection of the financial well-being of an organization, its legal rights, and the rights of its citizens or employees; a record without which an organization cannot carry out its business

*(birth, death and marriage definition)* a birth, death, or marriage record maintained by the official registrar of a New York State local government or by the New York State Department of Health